



IRAN SAMENCO.



MACHINERY & EQUIPMENT CONSTRUCTION





WASHING AND SEPARATING SAND MACHINERY



FEEDERS :

VIBRATOR & MECHANICAL FEEDER WITH TWO ARMS, CAPACITY 150 TO 250 t/h. EQUIPPED WITH ADJUSTABLE DISCHARGE GATE AND BIN FOR AGGREGATE STORAGE.



TYPE	CAPACITY T/H	POWER	SIZE
RMF 100	150 - 200	7.5 HP	0 - 100 mm
RMF 120	200 - 250	10 HP	0 - 100 mm



VIBRATING SCREEN :

VIBRATING SCREEN ; 3 STORIES , IN 5 DIFFERENT TYPES SURFACES FROM 4 x 150 TO 6 x 2m., CAPACITY 60 TO 250 t/h SINGLE AND TWIN SHAFT , WITH A REGULAR VIBRATION ALL SURFACES THE SCREEN. EASY CHANGING THE PARTS.

TYPE	CAPACITY T/H	R.P.M	POWER	SIZE
RMS 1000	60 - 100	1000	HP 7.5	400 x 150
RMS 12000	100 - 140	1000	HP 7.5	450 x 150
RMS 15000	150 - 180	1000	HP 10	500 x 150
RMS 16000	180 - 200	1000	HP 15	600 x 150
RMS 18000	200 - 250	1000	HP 20	600 x 200

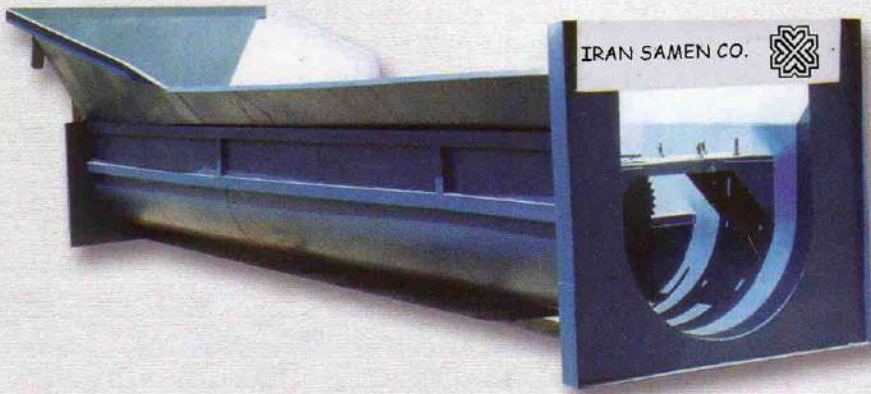

SAND WASHING MACHINE (SPIRAL TYPE) :

SAND WASHING MACHINE (SPIRAL TYPE) IN DIFFERENT LENGTH 6 TO 8 m. AND DIFFERENT CAPACITY 70 TO 160 t/h .

TYPE	CAPCITY T/H	POWER	DIAMETER	LENGTH
RMW 120	70 - 80	HP 15	120 CM	750 CM
RMW 180	80 - 120	HP 20	140 CM	800 CM



SCOOP WHEEL BUCKET :

IS USED IN HIGH CAPACITY FOR SAND AND GRAVEL PLANTS.

BELT CONVEYORS :

CONVEYORS IN DIFFERENT WIDTH (50 TO 120 cm) AND DIFFERENT LENGTHS ACCORDING TO BUYERS REQUIREMENTS.

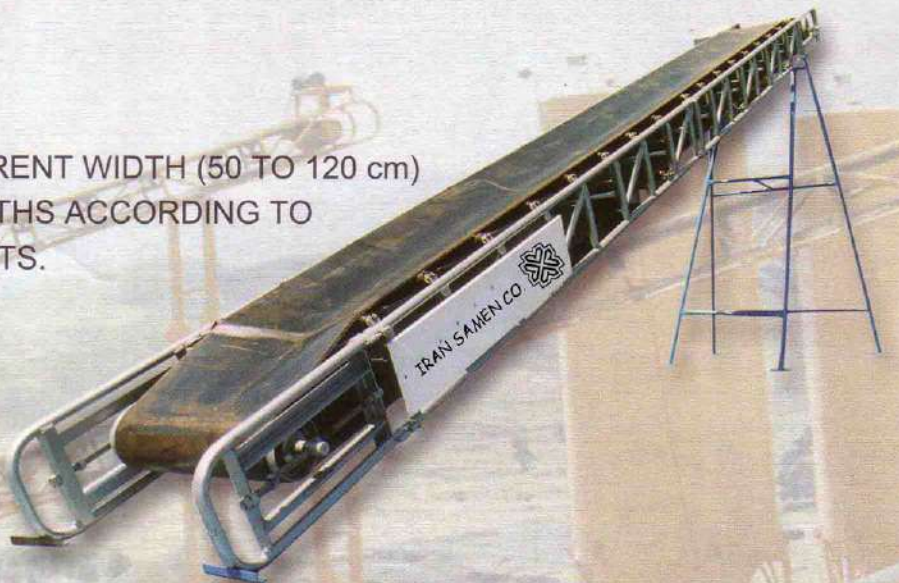

ISO 9001
CERTIFIED ORGANIZATION

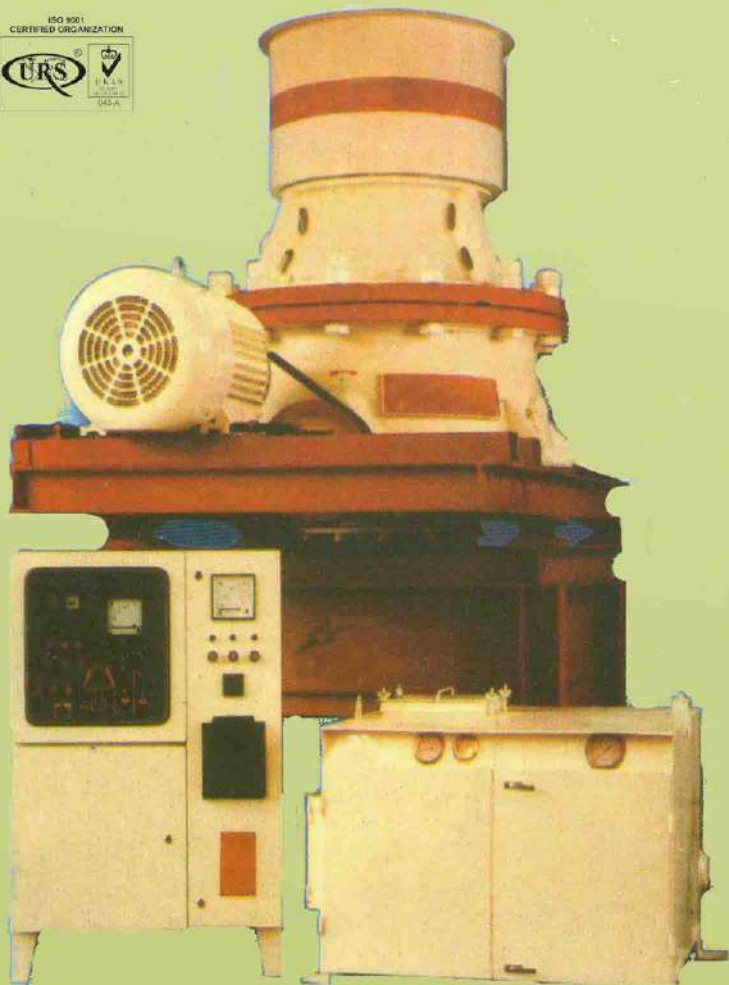

MOBILE CRUSHER MODAL I.S.G1200JI

کارخانه سنگ شکنی سیار مدل 1002JI



- قابلیت نصب سریع و آسان بدون نیاز به فونداسیون
- صرفه جویی قابل توجه در هزینه های حمل و نقل مصالح
- غیر ترافیکی بودن از نظر ابعاد و وزن در هنگام حمل
- مقاوم بودن مسیر حرکت سنگ در برابر سایش
- ظرفیت تولید ۱۰۰ تن بر ساعت با قابلیت ۱ تا ۵ نوع دانه بندی (پروژه های سد سازی، راه سازی و فرآوری معادن)

کارخانه سنگ شکنی سیار مدل J1002

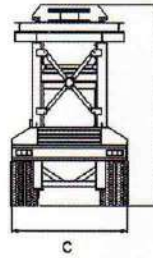
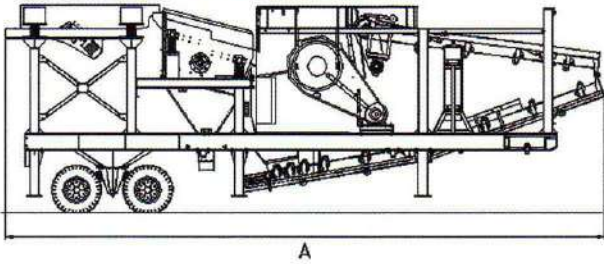

مرحله اول خردایش اجزاء اصلی شاسی اول:

فیدر ویبره ای
سرنند گریزلی دو طبقه
سنگ شکن فکی
نوار نقاله خروجی اصلی
نوار نقاله خاک
تابلو برق

Dimensions(on transit)	A	B	C	Weight (on Transit) (ton)	Max. Required power (kw)
ابعاد در هنگام حمل	11m	4.4m	2.5m	29	102

مشخصات فنی فیدر

TYPE	CAPACITY (tph)	SIZE (mXm)	FEED HOPPER CAPACITY (m ³)	POWER (kw)
Vibratory	60-150	1x3	7	2x3

مشخصات فنی سرنند گریزلی

TYPE	CAPACITY (tph)	SCREEN AREA (mXm)	POWER (kw)
Grizzly (Double deck)	60-150	1x2	7.5

مشخصات فنی سنگ شکن فکی

TYPE	APPROX. CAPACITY (tph)	OPENING SIZE (cmXcm)	POWER (kw)
Jaw Crusher Single toggle	100	90X50	75

مرحله دوم خردایش

اجزاء اصلی شاسی دوم:

سنگ شکن ضربه ای
سرنند سه طبقه ارتعاشی
نوار نقاله های رو و زیر سرنند ارتعاشی
نوار نقاله های محصول
تابلو برق

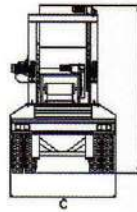
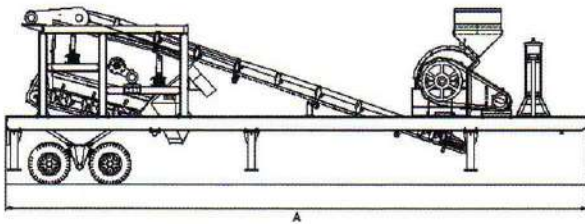

Dimensions(on transit)	A	B	C	Weight (on Transit) (ton)	Max. Required power (kw)
ابعاد در هنگام حمل	14m	4.4m	2.5m	29	117

مشخصات فنی سنگ شکن ضربه ای

TYPE	APPROX. CAPACITY (tph)	LARGEST FEED (mm)	POWER (kw)
Impact (8 Hammer)	100	150	90

مشخصات فنی سرنند ارتعاشی

TYPE	CAPACITY (tph)	SCREEN AREA (mXm)	POWER (kw)
Vibrating (3 Deck)	60-150	4x1.2	7.5

IMPACT CRUSHER Model P103

**DOUBLE WIDTH ROTOR
8 HAMMER**

Dimensions

Model No.	A mm	B mm	C mm	D mm	E mm	F mm	G mm
P 103	2060	2230	1860	1850	1250	1000	1410

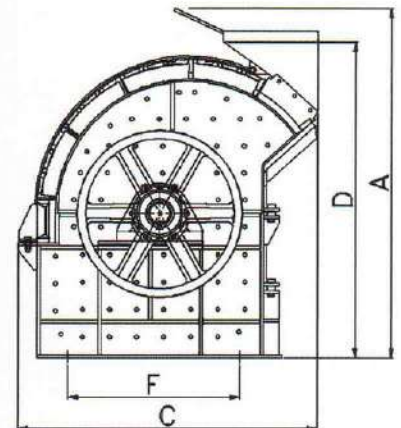
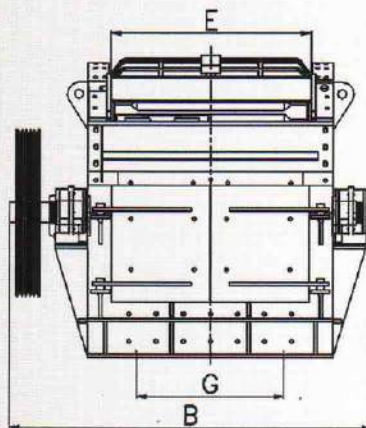
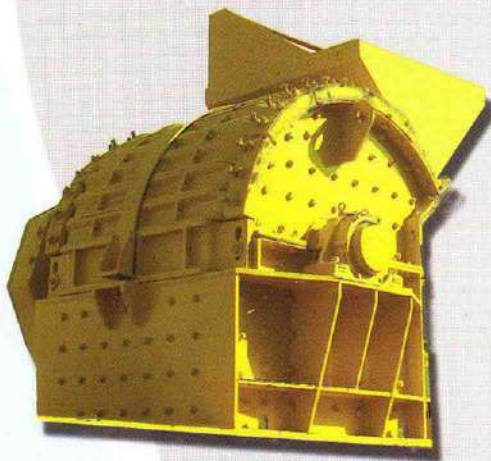

Data

Model No.	Approximate Hourly Capacity Tonnes	Largest Occasional Feed mm	Recommended Size of Feed mm	Approx. H.P. to drive	Max Feed Size mm
P 103	80-100	150	75 & under	90-110	250

Model No.	Size of drive pulley (Dia × Width) mm	Recommended Min/Max Speeds		Vee belts fitted	Approximate net weight Tonnes
		Minimum R.P.M.	Maximum R.P.M.		
P 103	1000 × 85	350	550	5 SPC	8.5

ISO 9001
CERTIFIED ORGANIZATION



CONCRETE MIXING MACHINERY



ADVANTAGES :

- 1- SIMPLICITY IN DESIGNING**
- 2- EASY EXPLOITATION**
- 3- EASY ACCESS TO SPARE PARTS**
- 4- LIABILITY FOR ERECTION AND INSTALLATION IN DIFFERENT CONDITIONS**
- 5- ERECTING AND DISASSEMBLING IN A SHORT TIME**
- 6- AFTER SALE CONTINUOUS AND FAST SERVICES**





MECHANICAL SCALING SYSTEM FOR WEIGHING AGGREGATES AND CEMENT BY USING OF UNTI-FRICTION AND WITH HIGH RESISTANCE COMBINATORIAL STEEL AND GAUGE FOR SHOWING THE WEIGHT AND ALSO DIGITAL AND ELECTRONICAL WEIGHING CEMENT AND AGGREGATE SYSTEMS.

- PENUMATIC BOX (PANEL)
- RELEVANT VALVES AND REGULATOR FILTER TO REGULATE THE AIR PRESSURE VALVES REQUIREMENT AND ALSO CONTINUOUS GREASING OF CIRCUIT AND VALVES INNER PLACES.

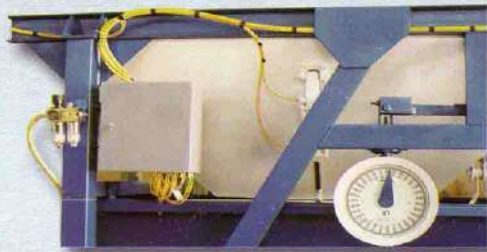

ELECTRICAL PANEL, FULL CAPACIOUS AND WHEEL'S KEYBOARD WITH ENOUGH SPACE BETWEEN KEYS, MAIN KEY AND EMERGENCY CUT OFF KEYS, CONTACTORS, BIMTALS AND OTHER HIGH QUALITY ELECTRICAL EQUIPMENTS.

OPERATOR'S CABIN WITH FULL LIGHT AND VISION THROUGH 4 SIDE WHICH ENABLE THE OPERATOR TO CONTROL ALL PARTS OF THE MACHINE . THE CABIN IS MADE OF PREVENTATIVE AND MULTI-PARTITION TO PREVENT FROM PENETRATION OF COLD AND HOT AIR.



OTHER EQUIPMENT :





QUALITY SUMMIT NEW YORK

2 0 0 3

Certificate

NEW YORK CONVENTION 2003

IRAN SAMEN CO.

awarded with the

QUALITY SUMMIT NEW YORK 2003

GOLD AWARD FOR EXCELLENCE
AND BUSINESS PRESTIGE

In recognition of the continuous search for
quality demonstrated by the achievement
of ongoing development and innovation
applied to solutions which create business results

New York, 14th of July, 2003



José E. Prieto
President of Business Initiative Directions

This certificate is awarded by

UNITED



Registrar of Systems Ltd



Registration Number 043-A

The use of the Accreditation Mark indicates
certification in respect of those activities covered
by the accreditation certificate number 043

Certificate of Registration

This certificate has been awarded to

IRAN SAMEN CO.

No.3, 2nd Floor, Cross of Shadab Street,
Gharani Street,
Tehran,
Iran

in recognition of the
organization's Quality System which complies with

ISO 9001:2000

The scope of activities covered by this certificate are defined below

**Trading, After Sale Services, Engineering Support Services for Industrial
Machines and Equipment**

Certificate Number: 15400 Issue No. 1

Date of Issue: 19 October 2005

Expiry Date: 31 October 2008

Issued by:

*On behalf of the
Schemes Manager*





IRAN SAMEN Co.



Head Office:

No.3,2nd fl,3bl.,cross of Shadab St.,Gharani St.,Tehran,Iran

Tel:+98(21)88915465-8 mobile: +989121215222 (Dr. gieahpour)

Fax:+98(21)88915469

P.O.BOX:14185-366

E-mail:samen@samengroup.com

Turkmenistan office:

No.102.,Ashgabat Business Center(ABC) Archabil Ave.,1939.,Ashgabat,Turkmenistan

Tel:+99(312)488825,489229 Tel: +79685099218 (Zadayan Armen Aramaisovich)

Tel/Fax:+99(312)488516

E-mail:samengroup@online.tm

Web-Site:www.samengroup.com



Иран Самин Со.

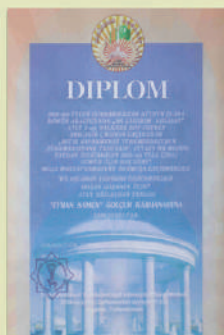

Голоиной офис Компфнии:

NO.3,2 зтфж,3блок,перекресток улиц Шадаб и Гарани, Тегеран , Иран

Тел:+98(21)88915465-8 мобильный: +989121215222 (Dr. gieahrour)

Факс:+98(21)88915469

P.O.BOX:14185-366

E-mail:samen@samengroup.com

Офис в Туркменистане:

Но:102, Ашгабатский Бизнес центр (АВС)Арчабиль шаелы1939,

Тел:+99(312)488825,489229 Тел: +79685099218 (Задаян Армен Арамаисович)

Тел/Факс:+99 (312)488516

E-mail:samengroup@online.tm

Web-Site: www.samengroup.com